

TRAP SEAL: PROVIDE SURESEAL INLINE FLOOR DRAIN TRAP SEAL. COMMERCIAL GRADE UV AND OZONE RESISTANT ABS PLASTIC HOUSING WITH PROPRIETARY EPDM RUBBER DIAPHRAGM AND SOFT RUBBER SEALING GASKET. FLOOR RATING ASSE-1072 AF-GW. INSTALL PER MANUFACTURE'S RECOMMENDATIONS.

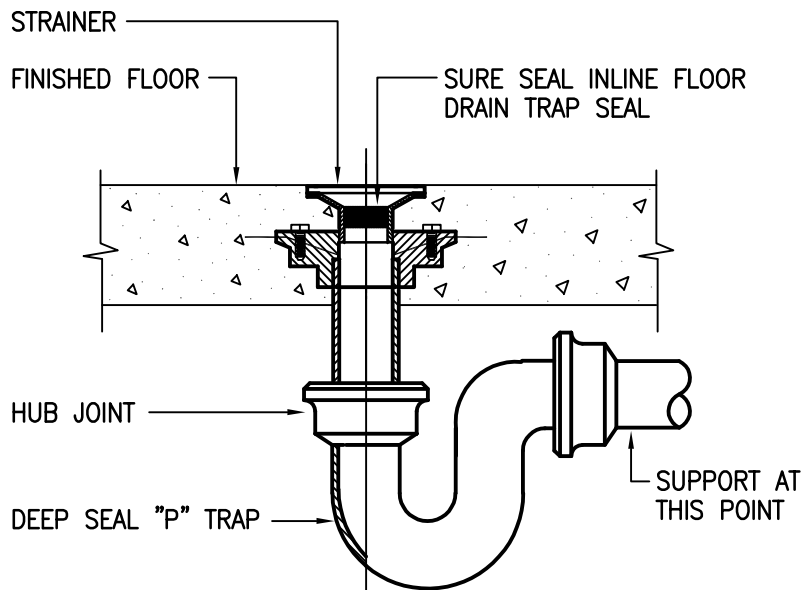

NOTES:

1. COMMERCIAL GRADE UV AND OZONE RESISTANT ABS PLASTIC HOUSING WITH PROPRIETARY EPDM RUBBER DIAPHRAGM AND SOFT RUBBER SEALING GASKET.
2. FLOOR SINK TRAP SEAL INSTALLATION IS SIMILAR.
3. INSTALLATION OF SURE SEAL INLINE FLOOR DRAIN TRAP SEAL TO BE IN ACCORDANCE WITH MANUFACTURER'S RECOMMENDATIONS.
4. FLOOR RATING ASSE - 1072 AF-GW.

FLOOR DRAIN WITH
TRAP SEAL PROTECTION

SCALE: NONE

X